

**WORLD COLLEGE OF TECHNOLOGY AND
MANAGEMENT,
GURGAON (HARYANA)**



**BASICS OF ELECTRONICS
(ECE-103 F)
LAB MANUAL
I, II SEMESTER
B. Tech.**

LIST OF EXPERIMENTS

S.NO.	Name of experiment	Page no.
1	To get familiar with working knowledge of the following Instruments (a) Cathode Ray Oscilloscope (b) The Multimeter Structure (c) Function generator (d) Regulated power supply	3-7
2	(a)To measure phase difference between two waveforms using CRO. (b) To measure unknown frequency from lissajous figures using CRO.	8-11
3	(a)Plot the forward and reverse V-I Characteristics of a PN junction Diode. (b)Calculation of cut in voltage (c)Study of Zener diode in Breakdown region. To plot and study the input and output chacterstics of BJT in	12-17
4	Common Emitter Configuration.	18-19
5	To find the frequency response of given(RC coupled) Amplifier and calculate its bandwidth.	20-22
6	To get familiar with pin configuration of typical OP-AMP 741 and its use as: (a)Inverting amplifier (b)Non-Inverting amplifier (c)summing amplifier (d)difference amplifier	23-25
7	Use of OP-AMP as: (a) Integrator (b)Differentiator	26-28
8	To assemble Wein bridge oscillator circuit and calculation of oscillation-frequency and its verification from the observed output.	29-30
9	Verification of Truth tables of logic gates(NAND, NOR, EX-OR, AND, OR, NOT).	31-33
10	Verification of Truth tables of Flip-Flops (S-R,J-K).	34-37

BASICS OF ELECTRONICS(ECE-103-F)

11	To get familiar with the working and use of seven segment display.	38-39
12	To Study Half – Wave Rectifier.	40-41
13	To study Light Emitting Diode	42-44

EXPERIMENT NO.1

AIM: To get familiar with working knowledge of the following Instruments:

- (a) Cathode Ray Oscilloscope(CRO)
- (b) Function Generator
- (c) Multimeter (Analog&Digital)
- (d) Power Supply

(a) CATHODE RAY OSCILLOSCOPE

The cathode-ray oscilloscope (CRO) is a common laboratory instrument that provides accurate time and amplitude measurements of voltage signals over a wide range of frequencies. Its reliability, stability, and ease of operation make it suitable as a general purpose laboratory instrument. The heart of the CRO is a cathode-ray tube shown schematically in Fig. 1.

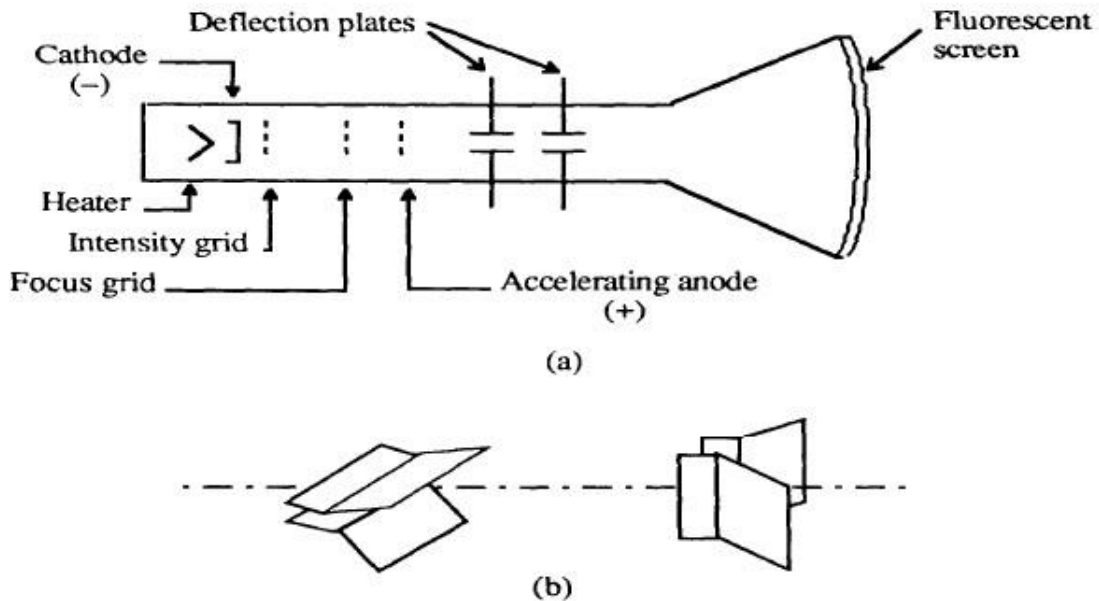

Figure 1. Cathode-ray tube: (a) schematic, (b) detail of the deflection plates.

The cathode ray is a beam of electrons which are emitted by the heated cathode (negative electrode) and accelerated toward the fluorescent screen. The assembly of the cathode, intensity grid, focus grid, and accelerating anode (positive electrode) is called an electron gun. Its purpose is to generate the electron beam and control its intensity and focus. Between the electron gun and the fluorescent screen are two pair of metal plates - one oriented to provide horizontal deflection of the beam and one pair oriented to give vertical deflection to the beam. These plates are thus referred to as the horizontal and vertical deflection plates. The combination of these two deflections allows the beam to reach any portion of the fluorescent screen. Wherever the electron beam hits the screen, the phosphor is excited and light is emitted

BASICS OF ELECTRONICS(ECE-103-F)

from that point. This conversion of electron energy into light allows us to write with points or lines of light on an otherwise darkened screen.

The voltage output of such a generator is that of a sawtooth wave as shown in Fig. 2. Application of one cycle of this voltage difference, which increases linearly with time, to the horizontal plates causes the beam to be deflected linearly across the tube face. When the voltage suddenly falls to zero, as at points (a) (b) (c), etc...., the end of each sweep - the beam flies back to its initial position. The horizontal deflection of the beam is repeated periodically, the frequency of this periodicity is adjustable by external controls.

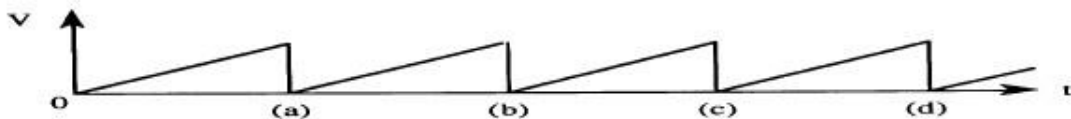
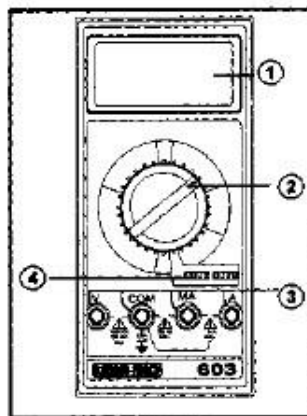

Figure. 2. Voltage difference V between horizontal plates as a function of time t .

D To obtain steady traces on the tube face, an internal number of cycles of the unknown signal that is applied to the vertical plates must be associated with each cycle of the sweep generator. Thus, with such a matching of synchronization of the two deflections, the pattern on the tube face repeats itself and hence appears to remain stationary. The persistence of vision in the human eye and of the glow of the fluorescent screen aids in producing a stationary pattern. In addition, the electron beam is cut off (blanked) during flyback so that the retrace sweep is not observed

(b) MULTIMETER



A multimeter is used to make various electrical measurements, such as AC and DC voltage, AC and DC current, and resistance. It is called a multimeter because it combines the functions of a voltmeter, ammeter, and ohmmeter. Multimeters may also have other functions, such as diode and continuity tests. The descriptions and pictures that follow are specific to the Fluke 73 Series III Multimeter, but other multimeters are similar.

(c) FUNCTION GENERATOR

A **function generator** is a device that can produce various patterns of voltage at a variety of frequencies and amplitudes.

- It is used to test the response of circuits to common input signals. The electrical leads from the device are attached to the ground and signal input terminals of the device under test.

Features and controls

- Most **function generators** allow the user to choose the shape of the output from a small number of options.
 - -Square wave - The signal goes directly from high to low voltage.
 - -Sine wave - The signal curves like a sinusoid from high to low voltage.
 - -Triangle wave - The signal goes from high to low voltage at a fixed rate.
- The amplitude control on a **function generator** varies the voltage difference between the high and low voltage of the output signal.
- The direct current (DC) offset control on a **function generator** varies the average voltage of a signal relative to the ground.
- The frequency control of a **function generator** controls the rate at which output signal oscillates. On some **function generators**, the frequency control is a combination of different controls.
- One set of controls chooses the broad frequency range (order of magnitude) and the other selects the precise frequency. This allows the **function generator** to handle the enormous variation in frequency scale needed for signals.

(d) POWER SUPPLY

There are many types of power supply. Most are designed to convert high voltage AC mains electricity to a suitable low voltage supply for electronics circuits and other devices. A power supply can be broken down into a series of blocks, each of which performs a particular function.

For example a 5V regulated supply:

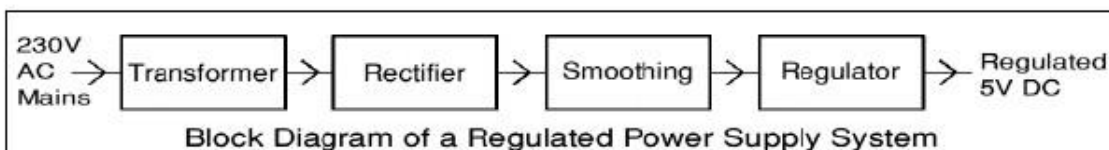

Each of the blocks is described in more detail below:

- Transformer - steps down high voltage AC mains to low voltage AC.
- Rectifier - converts AC to DC, but the DC output is varying.
- Smoothing - smoothes the DC from varying greatly to a small ripple.
- Regulator - eliminates ripple by setting DC output to a fixed voltage.

BASICS OF ELECTRONICS(ECE-103-F)

Quiz:

Q1: What are the uses of CRO?

A: Calibrate an oscillator, Compare two frequency generators ,Phase shift determination b/w V and I in any CRT circuit , study Beats phenomenon , study Lisajjous figures.

Q2: For what electron gun assembly is provided in a CRT?

A: To provide a narrow& sharply focused electron beam

Q3: What is meant by deflection sensitivity of a CRO?

A: Vertical deflection of the beam on the screen per unit deflecting voltage

Q4: What is the deflection factor of a CRO?

A: Reciprocal of deflection sensitivity.

Q5: What is a CRO?

A:Electronic device is an electronic device with a CRT as its main component & other associated ckts consisting of a power supply unit, a saw-tooth wave generator, horizontal & vertical amplifiers.

Q6: What is a function generator?

A: It is a signal source that has capability of producing different types of waveforms & frequencies

Q7: How the frequency of a function generator is controlled?

A: By varying the magnitude of current that drives the integrator

Q8: What is a regulated power supply?

A: An electronic ckt. Which provide constant DC voltage of predetermined value across load terminals , which is independent of variations in load current.

Q9: What are the basic components of a regulated power supply?

A: A transformer, rectifier ckt, filter, voltage regulator

Q10: What is the need of voltage regulators?

A: To keep output voltage constant against variations in load current & in AC mains voltage .

EXPERIMENT NO. 2

AIM: (a) To measure phase difference between two waveforms using CRO.
(b) To measure unknown frequency from lissajous figures using CRO.

APPARATUS: CRO, Function generator, Digital Voltmeter, Connecting Wires.

CIRCUIT DIAGRAM;

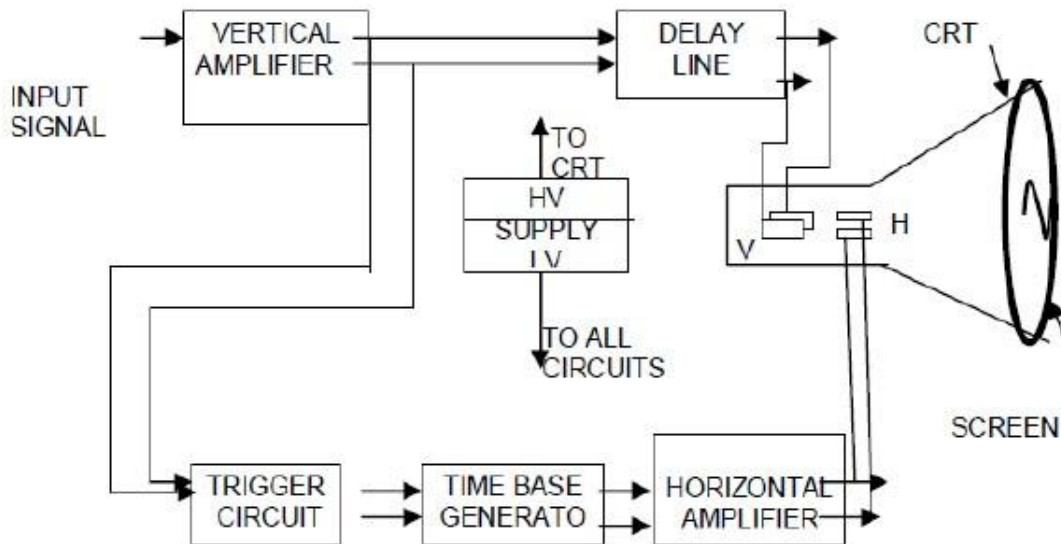

An oscilloscope is a measuring device used commonly for measurement of voltage, current, frequency, phase difference and time intervals. The heart of the oscilloscope is the cathode ray tube, which generates the electron beam, accelerates the beam to high velocity, deflects the beam to create the image, and contains the phosphor screen where the electron beam eventually becomes visible. To accomplish these tasks, various electrical signals and voltages are required. The power supply block provides the voltages required by the cathode ray tube to generate and accelerate the electron beam, as well as to supply the required operating voltages for the other circuits of the oscilloscope. Relatively high voltages are required by the cathode tubes, on the order of a few thousand volts, for acceleration, as well as a low voltage for the heater of the electron gun, which emits the electrons. Supply voltages for the other circuits are various values usually not more than few hundred volts.

The oscilloscope has a time base, which generates the correct voltage to supply the cathode ray tube to deflect this part at a constant time dependent rate. The signal to be view is fed to you vertical amplifier, which increases the potential of the input signal to a level that will provide a usable deflection of the electron beam. To synchronize the horizontal deflection the vertical input, such that the horizontal deflection starts at the same point of the input vertical signal each time it sweeps, a synchronizing or triggering circuit is used. This circuit is the link between the vertical input and the horizontal time base.

BASICS OF ELECTRONICS(ECE-103-F)

Procedure:

Phase Measurement using Lissajous Patterns (X-Y Mode):

To Measure the phase difference of two sine waves their frequencies must be equal.

1. Connect a 1Volt peak-peak, 1KHz sine wave signal from the function generator to the horizontal input of the CRO.
2. Connect the output of phase shift network to the vertical input as shown in figure.
3. Adjust the vertical and horizontal gains properly for good display.
4. Observe Lissajous Patterns for different combinations of R and C values.

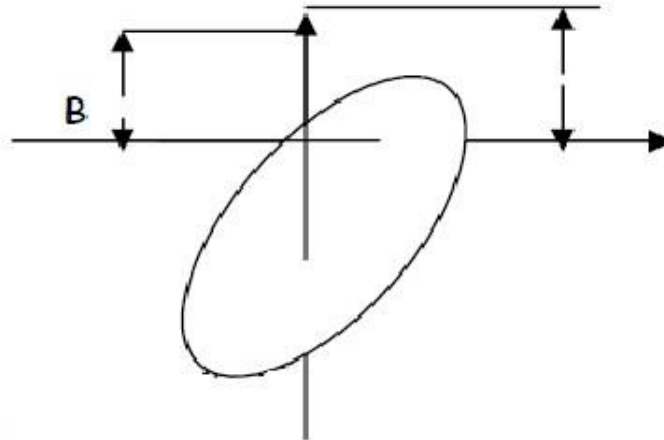

Calculate the phase angle as

$$\text{Sine } \phi = A/B$$

A: Distance between the points where the ellipse crosses the y-axis and the origin.

B: Distance between the origin and the y – co-ordinate of the maxima of the ellipse.

Calculate theoretical phase difference as

$$\theta = \tan^{-1} (f_1/f_2)$$

Where $f_2 = 1/2\pi RC$ $f_1 =$ input signal frequency.

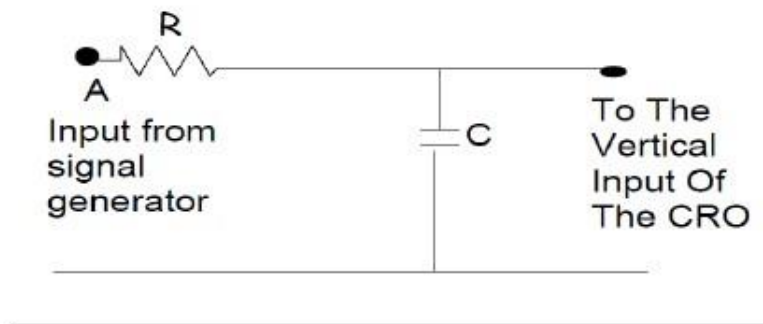

BASICS OF ELECTRONICS(ECE-103-F)

Phase Measurement Using Lissajous Pattern:

S.No	Lissajous Pattern	Practical Phase Difference (θ)	Theoretical Phase Difference (θ)

Result: The operation and applications of Cathode ray oscilloscope have been studied.

LISSAJOUS' FIGURES

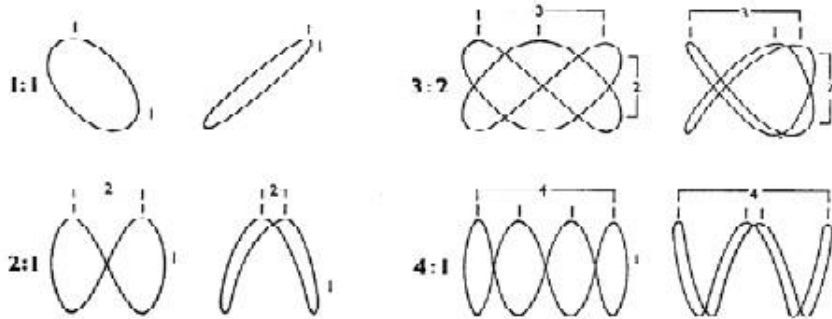

QUIZ

Q1: What is lissajous pattern?

A: Pattern that results from applying periodic signals to the deflection plates .

Q2: What is a CRO?

A: Electronic device is an electronic device with a CRT as its main component & other associated ckts consisting of a power supply unit, a saw-tooth wave generator, horizontal & vertical amplifiers.

Q3: What figure appear if the phase difference b etween the signals applied are 0 degree?

A: Straight line inclined at 45 degree to the positive X-axis

Q4: What figure appear if the phase difference between the signals applied are lies between 0 & 90 degree ?

A: Ellipse inclined at 45 degree to the positive X-axis

Q5: What figure appear if the phase difference between the signals applied is 90 degree?

A: Circle

Q6: What figure appear if the phase difference between the signals applied lies between 90 & 180 degree?

A: Ellipse inclined at 135 degree to the positive X-axis

Q7: What figure appear if the phase difference between the signals applied is 180 degree?

BASICS OF ELECTRONICS(ECE-103-F)

A: Straight line inclined at 135 degree to the positive X-axis.

Q8: For what vertical & horizontal plates are provided in a CRO?

A: To deflect the beam according to input signal.

Q9: For what a triggering ckt. Is provided in a CRO?

A: For synchronizing two types of deflections i.e horizontal & vertical

Q10: What is sweep time?

A: Time duration during which the beam is swept from left to right on the screen of a CRT.

EXPERIMENT NO: 3

AIM : (a)Plot the forward and reverse V-I Characteristics of a PN junction Diode.
(b)Calculation of cut in voltage
(c)Study of Zener diode in Breakdown region.

APPARATUS REQUIRED: Diode Characteristics Kit , Power Supply, Ammeter (0-20mA), Voltmeter (0-20V), Connecting Leads.Zener Diode.

BRIEF THEORY: A P-N junction is known as Semiconductor diode or Crystal diode. It is the combination of P-type & N-type Semiconductor which offers nearly zero resistance to current on forward biasing & nearly infinite Resistance to the flow of current when in reverse biased.

Forward biasing: When P-type semiconductor is connected to the +ve terminal and N-type to -ve terminal of voltage source. Nearly zero resistance is offered to the flow of current.

Reverse biasing : When P-type semiconductor is connected to the -ve terminal and N-type to +ve Terminal. Nearly zero current flow in this condition.

CIRCUIT DIGRAM :

(1) When diode is forward biased

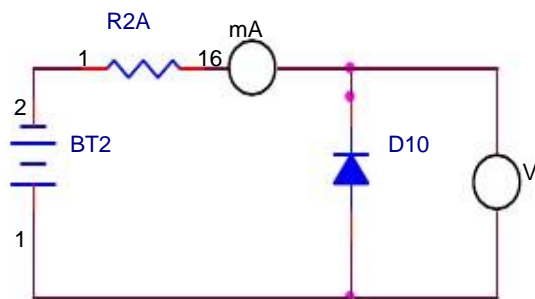

(2) When diode is reverse biased

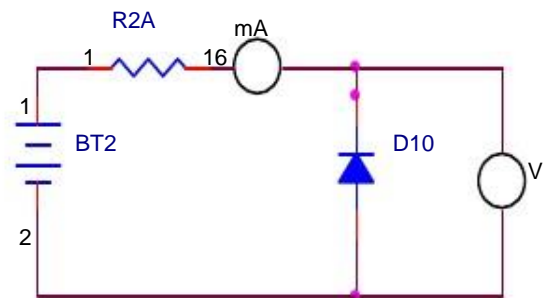

PROCEDURE:

- (1) Connect the ckt. as shown in fig.
- (2) Switch on the power supply.
- (3) Vary the value of input dc supply in steps.
- (4) Note down the ammeter & voltmeter readings for each step.
- (5) Plot the graph of Voltage Vs Current.
- (6) Connect the ckt. as shown in fig.

BASICS OF ELECTRONICS(ECE-103-F)

OBSERVATION TABLE :

S.NO.	When Diode Is Forward Biased		When Diode Is Reverse Biased	
	Current(mA)	Voltage(V)	Current(μ A)	Voltage(V)
1.				
2.				
3.				

GRAPH :

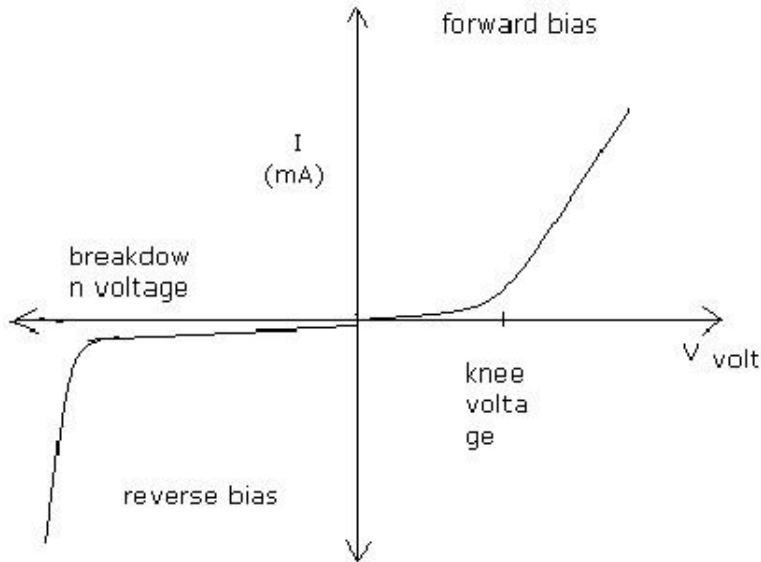

RESULT : The graph has been plotted between voltage and current.

(b) Calculation of knee voltage or cut in voltage.

For Si =

DISCUSSION: The diode do not conduct in RB state and conduct in FB state.

BASICS OF ELECTRONICS(ECE-103-F)

QUIZ :

Q1 : Define semiconductor diode.

A. A PN – junction is called semiconductor diode.

Q2: Define depletion layer.

A. The region having uncompensated acceptor and donor ions.

Q3: What do you mean by forward biased ?

A. When +ve terminal of battery is connected to P side & -ve terminal to N side of diode.

Q4: What do you mean by reverse biased ?

A. When +ve terminal of battery is connected to N side & -ve terminal to P side of diode.

Q5. Define Knee voltage.

A. The forward voltage at which current through the junction starts increasing rapidly.

Q6. Define breakdown voltage.

A. Reverse voltage at which PN junction breaks down with sudden rise in reverse current.

Q7. Define max. Forward current .

A. It is highest instantaneous forward current that a PN junction can conduct without damage to Junction.

Q8. Define max. Power rating .

A. Max. power that can be dissipated at junction without damage to it.

Q9. What is hole current?

A : The movement of hole from +ve terminal supply to negative terminal.

Q10: What is cut-in voltage ?

A: It is same as knee voltage.

(c) Study of Zener diode in Break down Region.

Specifications:

Breakdown Voltage = 5.1V

Power dissipation = 0.75W

Max. Forward Current = 1A

THEORY: An ideal P-N Junction diode does not conduct in reverse biased condition. A zener diode conducts excellently even in reverse biased condition. These diodes operate at a precise value of voltage called break down voltage. A zener diode when forward biased behaves like an ordinary P-N junction diode. A zener diode when reverse biased can either undergo avalanche break down or zener break down. Avalanche break down:-If both p-side and n-side of the diode are lightly doped, depletion region at the junction widens. Application of a very large electric field at the junction may rupture covalent bonding between electrons. Such rupture leads to the generation of a large number of charge carriers resulting in avalanche multiplication. Zener break down:-If both p-side and n-side of the diode are heavily doped, depletion region at the junction reduces. Application of even a small voltage at the junction ruptures covalent bonding and generates large number of charge carriers. Such sudden increase in the number of charge carriers results in zener mechanism.

CIRCUIT DIAGRAM:

Fig (1) – Forward Bias Condition:

Circuit Diagram:

Fig (1) - Forward Bias Condition:

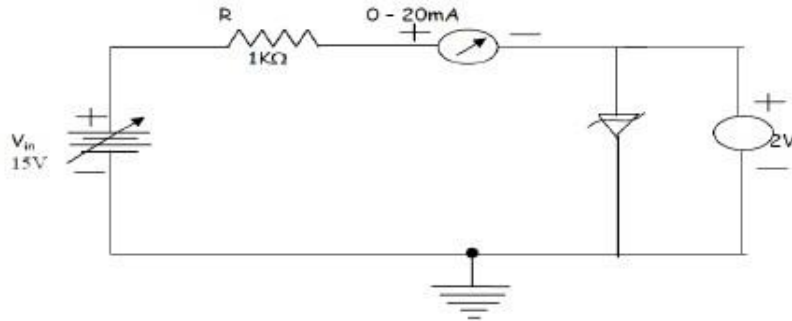
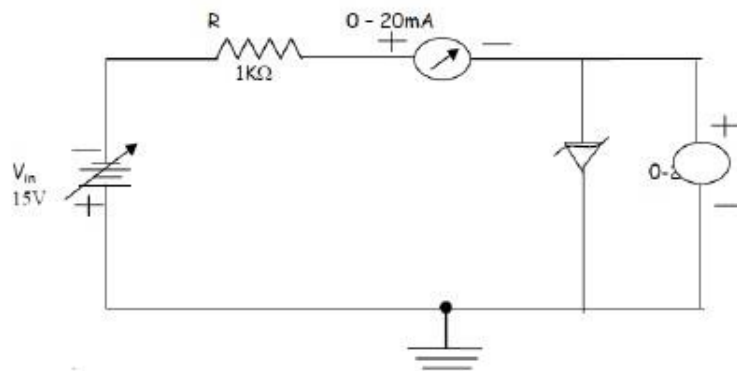

Fig (2) - Reverse Bias Condition:



PROCEDURE:

Forward biased condition:

1. Connect the circuit as shown in fig (1).
2. Vary V_{zf} gradually and note down the corresponding readings of I_{zf} .
3. Step Size is not fixed because of non linear curve and vary the X-axis variable (i.e. if output variation is more, decrease input step size and vice versa).
4. Tabulate different forward currents obtained for different forward voltages.

Reverse biased condition:

1. Connect the circuit as shown in fig (2).
2. Vary V_{zr} gradually and note down the corresponding readings of I_{zr} .

BASICS OF ELECTRONICS(ECE-103-F)

- Step Size is not fixed because of non linear curve and vary the X-axis variable (i.e. if output variation is more, decrease input step size and vice versa).
- Tabulate different reverse currents obtained for different reverse voltages.

Observations:

Zener diode in Forward Zener diode & reverse biased condition should be observed

Forward Voltage across the diode V_{zf} (volts)	Forward current through the diode I_{zf} (mA)	Reverse Voltage Across diode V_{zr} (volts)	Reverse current through the diode I_{zr} (mA)

Calculations from Graph:

Static forward Resistance $R_{dc} = V_f/I_f$

Dynamic forward Resistance $r_{ac} = \Delta V_f/\Delta I_f$

Static Reverse Resistance $R_{dc} = V_r/I_r$

Dynamic Reverse Resistance $r_{ac} = \Delta V_r/\Delta I_r$

PRECAUTIONS:

- While doing the experiment do not exceed the ratings of the diode. This may lead to damage the diode.
- Connect voltmeter and Ammeter in correct polarities as shown in the circuit diagram.
- Do not switch ON the power supply unless you have checked the circuit connections as per the circuit diagram.

RESULT:

- The zener diode characteristics have been studied.
- The zener resistance at the breakdown voltage was found to be =

QUIZ

Q1 : Give applications of Zener diode.

A : Applications of Zener diode are (a) Voltage regulation (b) Meter protection (c) Zener diode as a peak clipper (d) Zener diode as a reference element

Q2 : What is voltage regulation of Zener diode?

A : Voltage regulation is a measure of circuit's ability to maintain a constant output voltage even when either input voltage or load current varies.

Q3 :What is Zener current?

BASICS OF ELECTRONICS(ECE-103-F)

A : The Zener current in the breakdown region of Zener diode is called Zener current.

Q4: Give the equation from which series resistance of Zener diode regulator determined?

A : The equation from which series resistance of Zener diode regulator determined is

$RS = VS - VOUT / IZMAX$ where VS is source voltage, $VOUT$ is output voltage & $IZMAX$ is maximum current through Zener diode.

Q5 Give advantages of Zener diode regulator over other regulators.

A : Advantages of Zener diode regulator over other regulators are that they are smaller in size, lighter in weight and have longer life.

Q6 : What is Zener diode?

A : Zener diode, also sometimes called the breakdown diode is a P-N junction diode specially designed for operation in the breakdown region in reverse bias condition.

Q7: Give several methods used to manufacture of Zener diodes?

A: several methods used to manufacture of Zener diodes are diffused structure, diffused and passivated structure and alloy diffused structure.

Q8: In passivated structure of a Zener diode by which layer edges of the junction are covered?

A : In passivated structure of a Zener diode; Silicon Dioxide layer edges of the junction are covered.

Q9: Give the voltage range availability of Zener diodes?

A : The voltage range availability of Zener diodes is 2.4v to 200v.

Q10: What is Zener voltage?

A : The voltage at which the Zener diode breaks down is called the Zener voltage.

BASICS OF ELECTRONICS(ECE-103-F)

EXPERIMENT NO.4

AIM:- To plot and study the input and output characteristics of BJT in Common Emitter Configuration.

APPARATUS REQUIRED: Transistor Characteristic kit , Multimeter, Connecting leads and Power Supply .

THEORY: - In common Emitter configuration input is applied between base and emitter while the output is taken across emitter and collector. Thus the emitter forms the terminal common to both input and output circuits. The load resistance is connected at collector.

CIRCUIT DIAGRAM:-

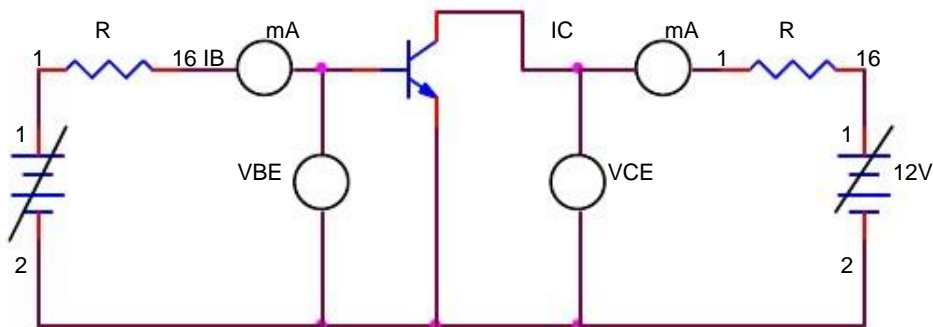

PROCEDURE:

(a) Connect the circuit as per the circuit diagram.

Input characteristics

- (b) Keep emitter - collector voltage constant.
- (c) Vary collector-base voltage in steps and note down base reading.
- (d) Readings are tabulated and graph is drawn

Output characteristics

- (a) Keep base current constant
- (b) Vary collector-emitter voltage in steps and note down emitter current
- (c) Readings are tabulated and graph is drawn

OBSERVATION TABLE :

S.No	Input charact.(Vce=Cons.)		Output charact. (Ib = Const.)	
	Ib(mA)	Vbe(Volts)	Ic(mA)	Vce(Volts)
1.				
2.				
3.				
4.				

GRAPH:-

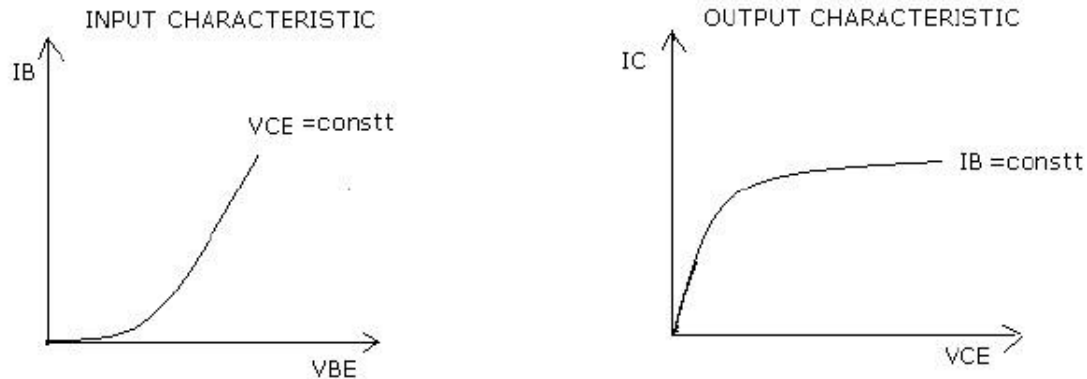

RESULT:-The input and output characteristic of transistor in common emitter configuration has been plotted.

DISCUSSION : With the help of output characteristics we can calculate AC& DC current gain in common emitter configuration.

PRECAUTIONS:

- (a) Connections should be tight.
- (b) Handle the equipments with care.

QUIZ:

Q1: What do you mean by biasing of transistor?

A. When dc voltages are applied across the different terminals of transistor, it is called biasing.

Q2: What is d.c. current gain in common base configuration?

A. It is ratio of collector current(I_c) to emitter current (I_e).

Q3: What is typical value for d.c. current gain ?

A. 0.99

Q4: What is a.c. current gain in CB configuration?

A. It is ratio of change in collector current to change in emitter current.

Q5: What are input characteristics?

A. These curves relate i/p current & i/p voltage for a given value of o/p voltage.

Q6: What are output characteristics?

A. The curves relate o/p voltage & o/p current for a given value of input current.

Q7: Which configuration has highest voltage gain?

A. Common Emitter.

Q8: Which configuration is most widely used?

A. Common Emitter.

Q9: What is operating point?

A. The zero signal values of I_c & V_{ce} .

Q10: Which region is heavily doped in Transistor?

A. Emitter.

EXPERIMENT NO.5

AIM: - To find the frequency response of given(RC coupled) Amplifier and calculate its Voltage gain.

APPARATUS REQUIRED: - CRO, function generator, breadboard, transistor BC 104 (2 pcs), capacitor $10\mu\text{F}$ (3 pcs), $100\mu\text{F}$ (2pcs), resistor 4.7K (2pcs), 5.6K (2pcs), 1K (2pcs), $\pm 12\text{ V}$ supply and connecting leads.

THEORY:

RC coupled amplifier is a coupling of two emitter biased transistor circuit to form a single cascade network. The output V_i of one stage is coupled to the input of the next stage. A blocking capacitor is used to keep the DC component of the output voltage at V_{o1} . The emitter resistor R_C and resistor R_1 and R_2 are used for biasing. The bypass capacitor is used to prevent loss of Amplification due to $-V_e$ feedback is C_2 output is taken across capacitor C_2 .

CIRCUIT DIAGRAM: -

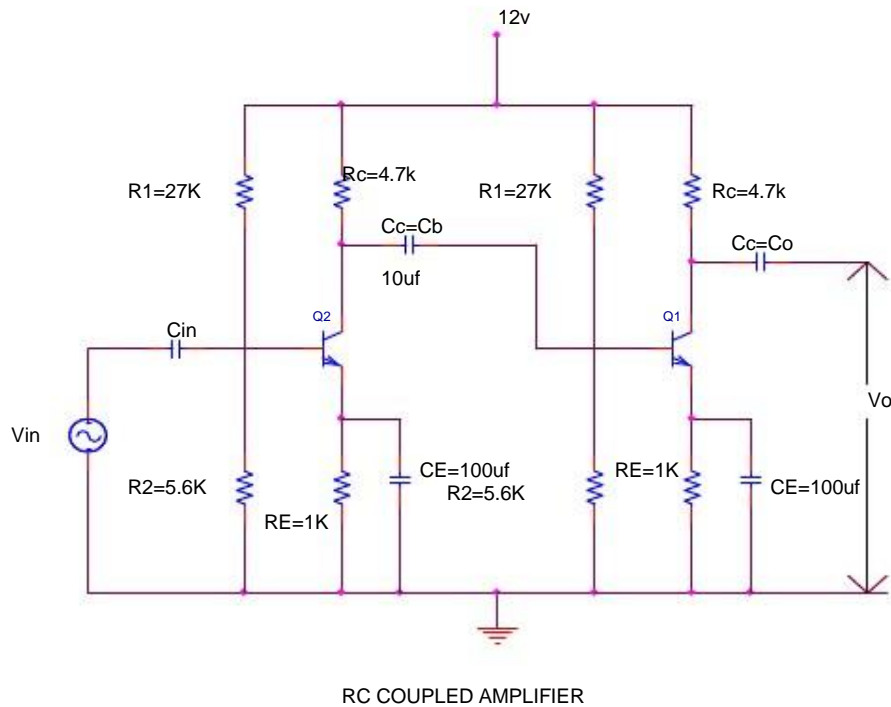

BASICS OF ELECTRONICS(ECE-103-F)

(4) Study the frequency response characteristics of RC coupled amplifier.

PRECAUTIONS:-

1. Do not use open ended wires for connecting to 230 V power supply?
2. Before connecting the power supply plug into socket, ensure power supply should be switched off.
3. Ensure all connections should be tight before switching on the power supply.
4. Take the reading carefully.
5. Power supply should be switched off after completion of experiment.

DISCUSSION:-What is the application of RC coupled amplifier?

RESULT: - The output of RC coupled amplifier is a sinusoidal wave having same phase as the input signal.

QUIZ:-

- Q.1. In RC coupled amplifier which component is responsible for reduction in voltage gain in the high frequency range?
A. Shunt capacitance in the input circuit.
- Q.2. In RC coupled amplifier which component's value is responsible for low 3-dB frequency?
A . Increasing the value of coupling capacitor C_b .
- Q.3. In RC coupled amplifier which component's value is responsible for high 3-dB frequency?
A . By reducing the total effective shunt capacitance in the input circuit of hybrid pie model.
- Q.4. In a single stage RC coupled amplifier, what is the phase shift introduced in the true middle frequency?
A . 180°
- Q.5. Which type of coupling capacitor is used in RC coupled amplifier?
A . $0.05 \mu\text{f}$ paper capacitor.
- Q.6. What is the application of RC coupled amplifier?
A It is widely used as a voltage amplifier.
- Q.7. In single stage RC coupled amplifier, what is the phase shift at low 3-dB frequency?
A . 225°
- Q.8. In single stage RC coupled amplifier, what is the phase shift at high 3-dB frequency?
A . 135°
- Q.9. In RC coupled amplifier what is the effect of low 3-dB frequency by Increasing the value of coupling capacitor C_b ?
A . Decreasing.
- Q.10. In RC coupled amplifier what is the effect of low 3-dB frequency by Increasing the value of total effective shunt capacitor?
A Decreasing.

EXPERIMENT NO. 6

AIM:- To get familiar with pin configuration of typical OP-AMP 741 and its use as:

- (a) Inverting amplifier
- (b) Non-Inverting amplifier
- (c) Summing amplifier
- (d) Difference amplifier.

APPARATUS REQUIRED:- CRO, Function Generator, Bread Board, 741 IC, $\pm 12V$ supply, resistors $1K\Omega$, $10K\Omega$, and connecting leads.

BRIEF THEORY:- The op-amp is a multi-terminal device used in a number of electronic circuits.

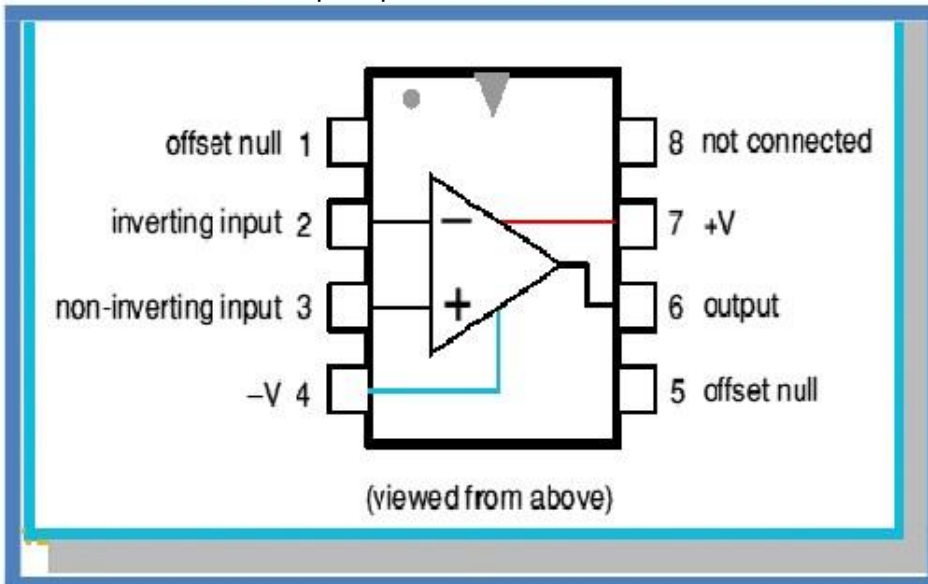

Inverting Amplifier:-

In the inverting amplifier only one input is applied and that is to the inverting input (V₂) terminal. The non-inverting input terminal (V₁) is grounded.

Since,

$$V_1 = 0V \text{ \& } V_2 = V_{in}$$
$$V_o = -A V_{in}$$

The -ve sign indicates the output voltage is 180° out of phase with respect to the input and amplified by gain A.

Non-Inverting Amplifier:- The input is applied to the non-inverting input terminal and the Inverting terminal is connected to the ground.

$$V_1 = V_{in} \text{ \& } V_2 = 0 \text{ volts}$$
$$V_o = A V_{in}$$

The output voltage is larger than the input voltage by gain A & is in phase with the input signal.

(c) Summing Amplifier:

If each input voltage is amplified by a different factor in other words weighted differently at the output, the circuit is called then scaling amplifier.

$$\frac{R_f}{R_a} \neq \frac{R_f}{R_b} \neq \frac{R_f}{R_c}$$

$$V_o = -\left(\frac{R_f}{R_a} V_a + \frac{R_f}{R_b} V_b + \frac{R_f}{R_c} V_c\right)$$

The circuit can be used as an averaging circuit, in which the output voltage is equal to the average of all the input voltages.

In this case, $R_a = R_b = R_c = R$ and $R_f / R = 1 / n$ where n is the number of inputs. Here $R_f / R = 1 / 3$.

$$V_o = -(V_a + V_b + V_c) / 3$$

In all these applications input could be either ac or dc.

(c) Difference Amplifier:

The output voltage is directly proportional to the input difference of two voltages:

$$V_o = (V_{in1} - V_{in2})$$

CIRCUIT DIAGRAM: -

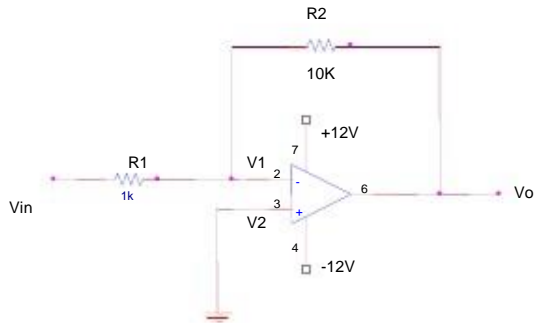

(a) INVERTING AMPLIFIER

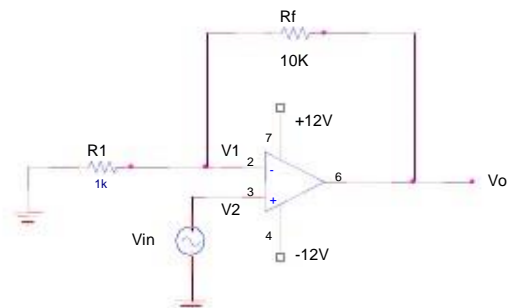

(b) NON-INVERTING AMPLIFIER

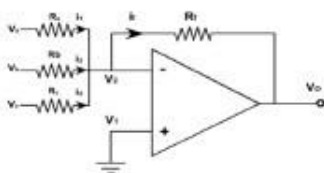

(c) Difference Amplifier

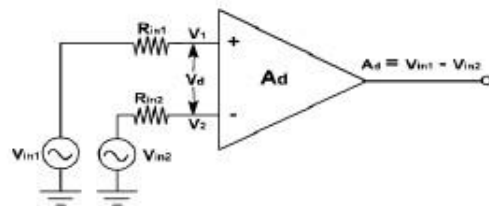

(d) Summing Amplifier

BASICS OF ELECTRONICS(ECE-103-F)

PROCEDURE: -

- (1) Connect the circuit for Inverting, Non-inverting and Summing & Difference amplifier on a Breadboard.
- (2) Connect the input terminal of the op-amp to function generator and output terminal to CRO.
- (3) Feed input from function generator and observe the output on CRO.
- (4) Draw the input and output waveforms on graph paper.

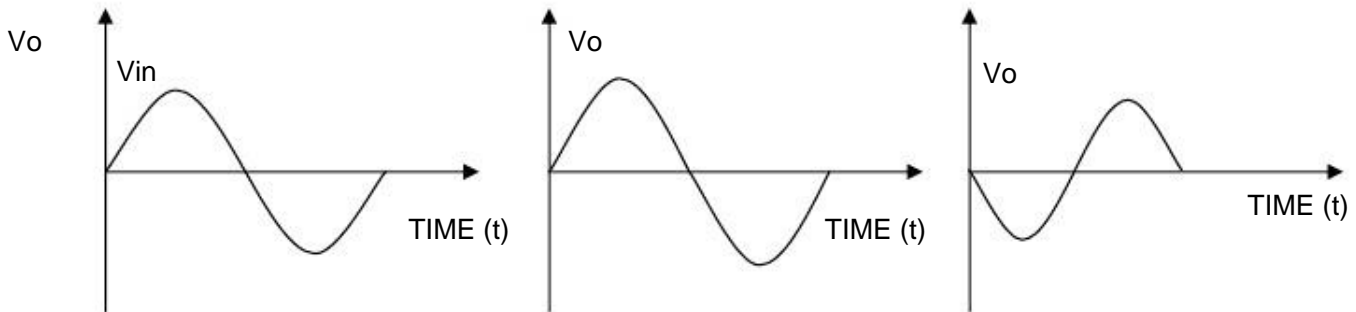

RESULT: - Desired & Amplified output waveforms are obtained.

PRECAUTIONS:-

1. Do not use open ended wires for connecting to 230 V power supply.
2. Before connecting the power supply plug into socket, ensure power supply should be switched off.
3. Ensure all connections should be tight before switching on the power supply.

QUIZ / ANSWERS:-

Q.1 What is the significance of a difference amplifier?

A .The differential amplifier is capable of amplifying dc as well as AC I/P signals.

Q.2. What are the applications of a differential amplifier?

A . In instrumentation systems

Q.3 What is the meaning of CMRR?

A . It is the ratio of the differential voltage gain A_d to the common mode voltage gain A_{cm} .

Q.4 What is the unit of CMRR?

A. Decibels (dB)

Q.5 What is the value of CMRR for the 742 IC ?

A . 90 dB

Q.6 What is the gain of the inverting amplifier in terms of resistances?

A . Gain $(- R_f/R_i)$

Q.7 What is the gain of the non- inverting amplifier in terms of resistances?

A . Gain $= (1+R_f/R_i)$

Q.8 What is the condition for averaging amplifier?

A. $R_f/R_i = 1/n$, where n is no. of inputs applied.

Q.9 What is the effect of -ve feedback on the voltage gain of an amplifier?

A . Increases the stability of its voltage gain.

Q.10 What is the meaning of gain of an amplifier with feedback?

A . Closed loop voltage gain

EXPERIMENT NO: 7

AIM: Use of OP-AMP as:

- (a) Integrator
- (b) Differentiator .

APPARATUS REQUIRED: CRO, Function Generator, Power supply, connecting leads, Differentiator & Integrator circuit kit.

THEORY:

(a) Integrator

In this circuit, the feedback resistor of an OP-AMP is replaced by a capacitor. The output obtained will be an integral of the input wave.

$$I(t) = v(t) / R$$

$$\text{Output Voltage} = \int \frac{1}{C} \frac{v(t)}{R} dt = -\frac{1}{RC} \int v(t) dt$$

The circuit therefore provides an output voltage proportional to the integral of the input voltage. If the input voltage is a constant, $v=V$, then the output will be a ramp,

$$v_o(t) = -\frac{1}{RC} \int v_i(t) dt$$

CIRCUIT DIAGRAM:

A circuit in which the output voltage waveform is the integral of the input voltage waveform is called integrator. **figure** shows an integrator circuit using OPAMP.

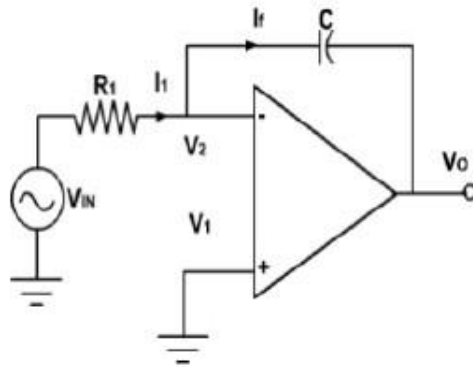
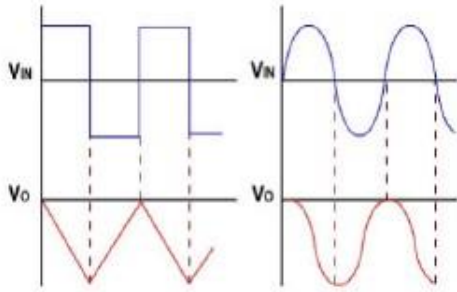

Fig.

Here, the feedback element is a capacitor. The current drawn by OPAMP is zero and also the V_2 is virtually grounded.

Therefore, $i_1 = i_2$ and $v_2 = v_1 = 0$

Waveform:



(b) Differentiator

In this circuit, the capacitor is connected in series with the input resistor. It is an electronic circuit in which the OP-Amp is employed in such a way that the output voltage comes out to be as a derivative of the input voltage. This type of circuit is called an OP-AMP differentiator. The output is proportional to the time derivative of the input wave.

$$\text{Output Voltage} = -R I = -RC \frac{d}{dt} V_{IN}$$

A circuit in which the output voltage waveform is the differentiation of input voltage is called differentiator as shown in Fig. .

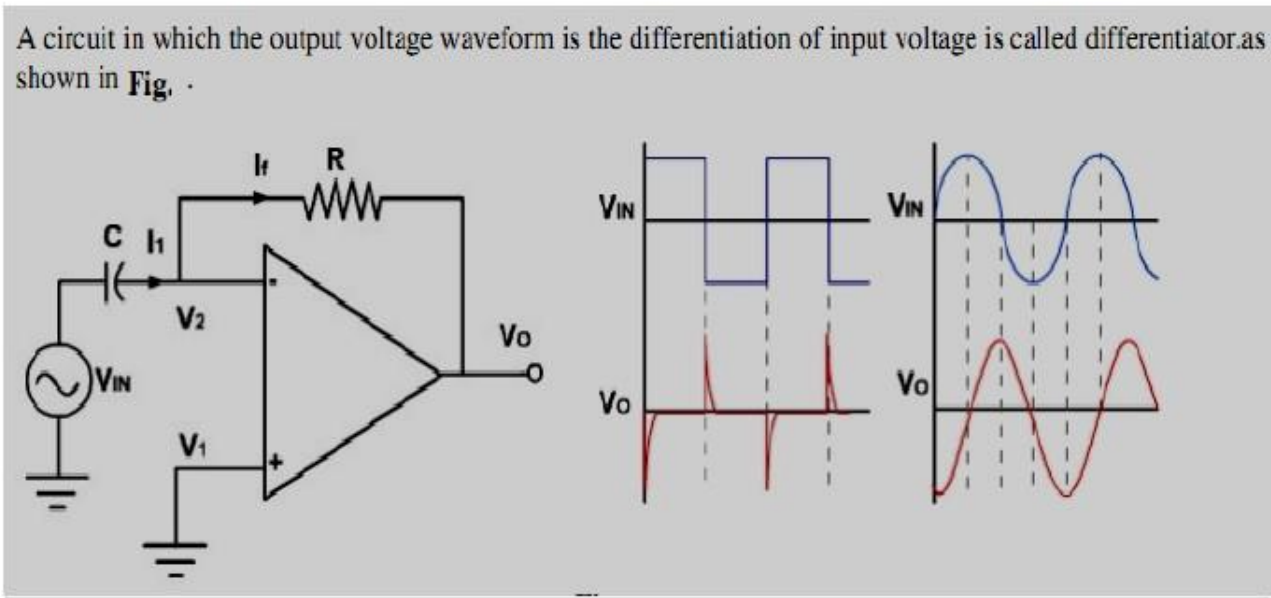

BASICS OF ELECTRONICS(ECE-103-F)

PROCEDURE:

1. Connect the circuit according to the diagram and switch on the power supply.
2. Supply the input wave to the input terminal of the given circuit.
3. Set the output voltage at 1 V peak and frequency at 1 KHz.
4. Observe the output waveform on the CRO.

RESULT

The output waveform is obtained and observed on the CRO.

PRECAUTIONS

1. Connect the circuit properly as shown in fig.
2. Set the input waveform of correct amplitude and frequency.
3. Connect the CRO to the output terminal.

QUIZ

- Q1: What is the input impedance of ideal op-amp?
A: Infinite
- Q2: What is the gain of ideal op-amp?
A: Infinite
- Q3: What is CMMR of an ideal op-amp?
A: Infinite
- Q4: Why negative feedback is essential in op-amp?
A: Decrease the gain so that the bandwidth increases since the gain bandwidth product is constant.
- Q5: What is virtual ground?
A: If one terminal of an op-amp is grounded also act as grounded this is known as virtual ground.
- Q6: Why the virtual ground concept is possible in op-amp?
A: Since it has infinite impedance and gain.
- Q7: What is the basic building block of an op-amp?
A: Differential Amplifier.
- Q8: What is integrator?
A: It is used to integrate the input signal.
- Q9: What is output of an integrator when input is square wave?
A: Triangular wave.
- Q10: The feedback component in an op-amp integrator is ----?
A: Capacitor.
-

BASICS OF ELECTRONICS(ECE-103-F)

EXPERIMENT NO: 8

AIM: To assemble Wein bridge oscillator circuit and calculation of oscillation-frequency and its verification from the observed output.

APPARATUS REQUIRED: Bread board, CRO, $\pm 12V$ power supply, Resistors $10K\Omega$, $20K\Omega$, $3.2K\Omega$, $0.05\mu f$, and connecting leads.

BRIEF THEORY: - In Wein bridge oscillator, Wein bridge circuit are connected between amplifier input and output terminal. The bridge have a series RC network in one arm and a Parallel RC network in adjoining arm, on the remaining two arms of bridge, resistor R_1 and R_f are connected. The phase angle criterion for oscillator is that the total phase shift around the circuit must be 0° . this condition occurs only when the bridge is balanced, i.e. at resonance. The frequency of oscillation f_0 is exactly the resonant frequency of the balanced wein bridge and is given by

$$f_0 = \frac{1}{2\pi RC} = 0.159/RC$$

CIRCUIT DIAGRAM:-

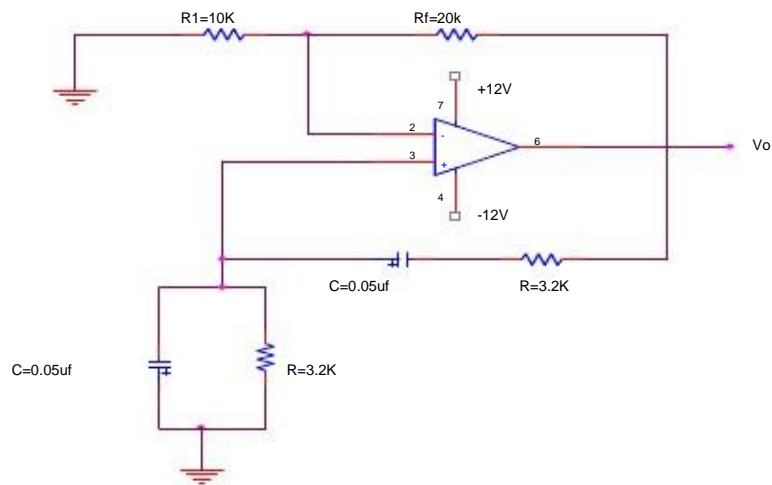

WEIN BRIDGE OSCILLATOR

WAVE FORM: -

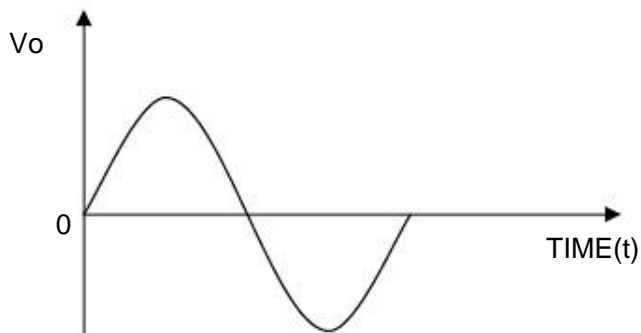

BASICS OF ELECTRONICS(ECE-103-F)

PROCEDURE: -

- (1) Connect the circuit as per the circuit diagram.
- (2) Switch 'on' the power supply.
- (3) Output of the circuit is shown on CRO.

DISCUSSION:- Wein bridge oscillator generates sine wave forms.

PRECAUTIONS:-

1. Do not use open ended wires for connecting to 230 V power supply?
2. Before connecting the power supply plug into socket, ensure power supply should be switched off
3. Ensure all connections should be tight before switching on the power supply.
4. Take the reading carefully.
5. Power supply should be switched off after completion of experiment.

RESULT: - Sine wave is generated on CRO.

QUIZ

Q.1 What is the oscillator?

Ans. The oscillator is a circuit that generates repetitive waveforms of fixed amplitudes and frequency without any external i/p signal.

Q.2 What is the application of the oscillator?

Ans. A radio, T.V., Computers and communications.

Q.3 What is the principle of the oscillator?

Ans. If the signal feedback is of proper magnitude and phase, the circuit produces alternating currents or voltage.

Q.4 What are the two requirements for oscillations?

- Ans. 1. Magnitude of the loop gain must be at least 1
2. Total phase shift of the loop gain must be equal to 0 or 360 degree.

Q.5 What is frequency stability?

Ans. The ability of the oscillator circuit to oscillate at one exact frequency is frequency stability.

Q.6 What is the total phase for oscillation?

Ans. 360 or 0 degree.

Q.7 What is the condition for wein bridge oscillator to balance?

Ans. Total phase shift around the circuit must be 0 degree.

Q.8 What is wein bridge oscillator?

Ans. Wein bridge oscillators have that circuit in which the wein bridge circuit is connected between the amplifiers i/p terminals and the o/p terminals.

Q.9 Which type of feedback used in oscillator?

Ans. +ve feedback

Q.10 What is the frequency response for a wein bridge oscillator?

Ans. $F = 0.159/RC$

EXPERIMENT NO: 9

AIM: Verification of Truth tables of logic gates(NAND, NOR, EX-OR, AND, OR, NOT).

APPARATUS REQUIRED: Power Supply, Digital Trainer Kit, Connecting Lead(7400, 7402,7404,7432,7408,7486)

BRIEF THEORY:

NAND GATE: The IC no. for NAND gate is 7400. The NOT-AND operation is known as NAND operation. If all inputs are 1 then output produced is 0. NAND gate is inverted AND gate.

NAND



$F = (xy)'$

x	y	F
0	0	1
0	1	1
1	0	1
1	1	0

NOR GATE: The NOR gate has two or more input signals but only one output signal. IC 7402 is two I/P IC. The NOT- OR operation is known as NOR operation. If all the inputs are 0 then the O/P is 1. NOR gate is inverted OR gate.

NOR



$F = (x + y)'$

x	y	F
0	0	1
0	1	0
1	0	0
1	1	0

EX-OR GATE: The EX-OR gate can have two or more inputs but produce one output. 7486 is two input IC. EX-OR gate is not a basic operation & can be performed using basic gates.

Exclusive-OR (XOR)



$F = xy' + x'y$
 $= x \oplus y$

x	y	F
0	0	0
0	1	1
1	0	1
1	1	0

AND GATE The AND operation is defined as the output as one if and only if all the inputs are one. 7408 is the two Input AND gate IC.A&B are the Input Terminals &Y is the Output terminal.

BASICS OF ELECTRONICS(ECE-103-F)

AND

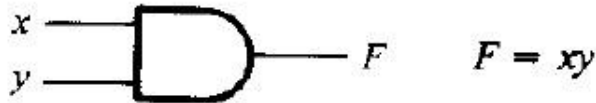

x	y	F
0	0	0
0	1	0
1	0	0
1	1	1

OR Gate: The OR operation is defined as the output as one if one or more than one inputs are one. 7432 is the two Input OR gate IC. A&B are the input terminals & Y is the Output terminal.

$$Y=A+B$$

OR

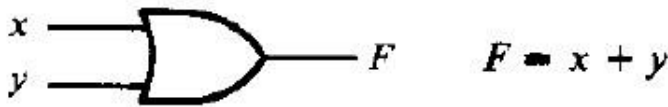

x	y	F
0	0	0
0	1	1
1	0	1
1	1	1

NOT GATE: The NOT gate is also known as Inverter. It has one input (A) & one output (Y). IC No. is 7404. Its logical equation is,

$$Y = \text{NOT } A$$

$$Y = A'$$

Inverter



x	F
0	1
1	0

PROCEDURE:

- (a) Fix the IC's on breadboard & give the input supply.
- (b) Connect the +ve terminal of supply to pin 14 & -ve to pin 7.
- (c) Give input at pin 1, 2 & take output from pin 3. It is same for all except NOT & NOR IC.
- (d) For NOR, pin 1 is output & pin 2&3 are inputs.
- (e) For NOT, pin 1 is input & pin 2 is output.
- (f) Note the values of output for different combination of inputs & draw the TRUTH TABLE.

BASICS OF ELECTRONICS(ECE-103-F)

OBSERVATION TABLE:

AND		OR		NOT		NORNAND				EX-OR	
I/P	O/P	I/P	O/P	I/P	O/P	I/P	O/P	I/P	O/P	I/P	O/P

RESULT: We have learnt all the gates ICs according to the IC pin diagram.

PRECAUTIONS:

- 1) Make the connections according to the IC pin diagram.
- 2) The connections should be tight.
- 3) The V_{cc} and ground should be applied carefully at the specified pin only.

QUIZ:

Q.1. Define gates ?

A1. Gates are the digital circuits, which perform a specific type of logical operation.

Q.2. Define IC ?

A2. IC means integrated circuit. It is the integration of no. of components on a common substrate.

Q3. Write the logical equation for AND gate

A3. $Y=A.B$

Q.4. $(A+A) A = ?$

A4. A

Q5. Define Universal gates.

A5. Universal gates are those gates by using which we can design any type of logical expression.

Q6. When will the output of a NAND Gate be 0 ?

A6. When all the inputs are 1.

Q7 How many no. of input variables can a NOT Gate have?

A7. One

Q8. Under what conditions the output of a two input AND gate is one?

A8. Both the inputs are one.

Q9. $1+0 = ?$

A9. One

Q10 Write the logical equation for OR gate.

A10 $Y=A+B$

BASICS OF ELECTRONICS(ECE-103-F)

EXPERIMENT NO: 10

AIM:- Verification of Truth tables of Flip-Flops (S-R,J-K).

APPARATUS REQUIRED: - IC 7400,IC 7404 etc. ,Power Supply, Digital Trainer Kit, Connecting Lead

BRIEF THEORY:

A clock signal is used to synchronize circuits. The cycle time reflects how long sequential operations take. Flip-flops further restrict the memory writing interval, to just the positive edge of the clock signal. This ensures that memory is updated only once per clock cycle. There are several different kinds of flip-flops, but they all serve the same basic purpose of storing bits. The tables that we've made so far are called characteristic tables. They show the next state $Q(t+1)$ in terms of the current state $Q(t)$ and the inputs

CIRCUIT DIAGRAM:

A) S-R Flip-Flop

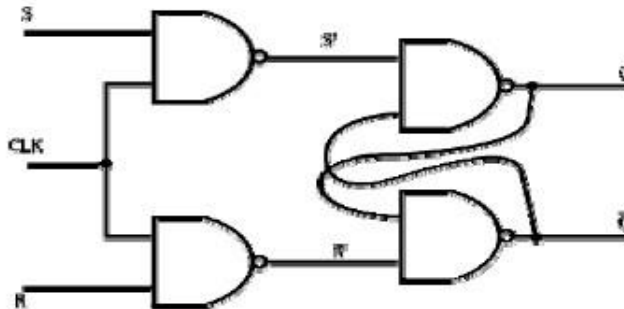

Q_n / \bar{Q}_n	R	S	Q_{n+1} / \bar{Q}_{n+1}
0 1	0	0	
1 0	0	0	
0 1	0	1	
1 0	0	1	
0 1	1	0	
1 0	1	0	
0 1	1	1	
1 0	1	1	

ii) D Flip-Flop

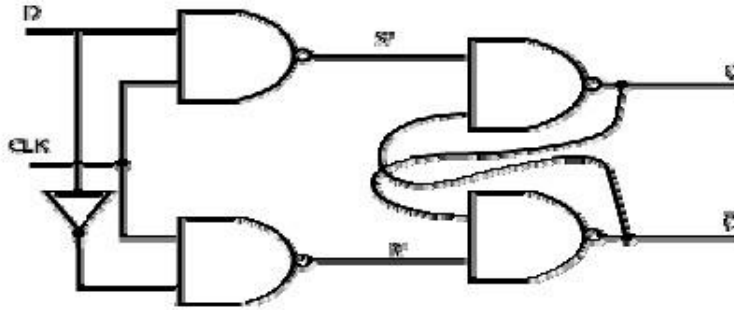

D Flip-Flop:-

Preset	Clear	D	Clock	Q_{n+1}	$\overline{Q_{n+1}}$
1	1	0		0	1
1	1	1		1	0

iii) T Flip-flop

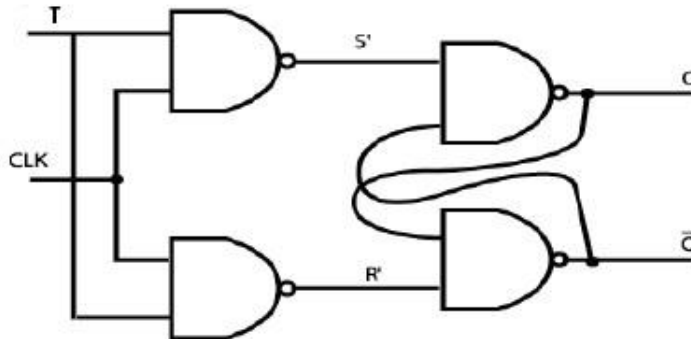

T Flip-Flop:-

Preset	Clear	T	Clock	Q_{n+1}	$\overline{\overline{Q_{n+1}}}$
1	1	0		Q_n	$\overline{Q_n}$
1	1	1		$\overline{Q_n}$	Q_n

IC 7476 M/S JK FLIP FLOP; -

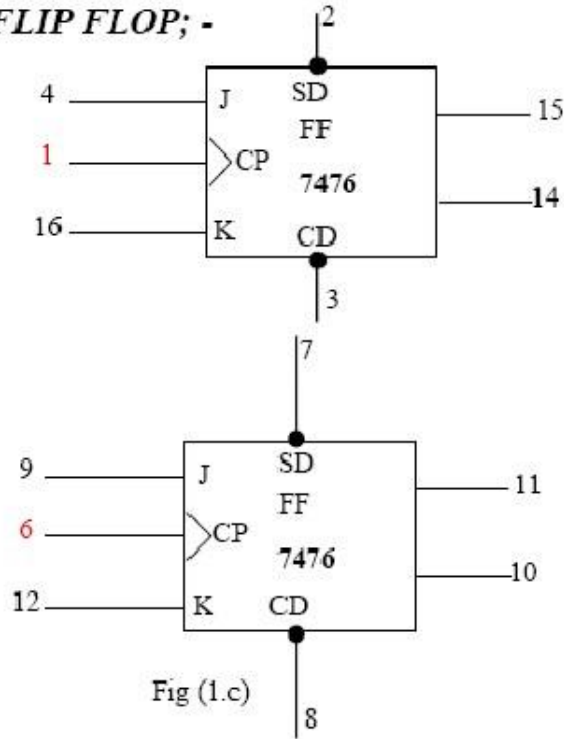

Fig (1.c)

TRUTH TABLE FOR JK-FLIP FLOP (IC 7476); -

SD Preset	CD Clear	Clock	J	K	OUTPUTS	
					Q	\bar{Q}
L	H	X	X	X	H	L
H	L	X	X	X	L	H
L	L	X	X	X	H*	H*
H	H	↓	L	L	Q ₀	\bar{Q}_0
H	H	↓	H	L	H	L
H	H	↓	L	H	L	H
H	H	↓	H	H	TOGGLE	
H	H	H	X	X	Q ₀	\bar{Q}_0

*Unstable condition. It will not remain after C_x and P_x inputs return to their inactive (high) state

PROCEDURE: -

1. Connections are made as per circuit diagram.
2. Verify the truth table for various combinations of inputs.

RESULT: We have learnt all the Flip-flops according to their ckt. diagrams & working operation.

BASICS OF ELECTRONICS(ECE-103-F)

PRECAUTIONS:

- 1) Make the connections according to the IC pin diagram.
- 2) The connections should be tight.
- 3) The Vcc and ground should be applied carefully at the specified pin only.

QUIZ

Q.1 What is difference between latch and flip flops?

A.1 Latch has no clocks but flip flops has clocks.

Q.2 For clocked flip flops which circuit we use?

A.2 RC Network

Q.4 What is the difference between combinational and sequential circuits?

A.4. Output in sequential depends on present inputs as well as previous outputs but in combinational only on present inputs

Q5: In which flip-flop Race around conditions occurs?

A5: J-K Flip flop

Q6: How race around condition is removed?

A6: By using Master slave J-K Flip flop

Q7: How edge triggering of flip-flops can be removed?

A7: Using R-C network

Q8: What is the full form of D flip flop?

A8: Delay flip flop

Q9: What is the full form of T flip flop?

A9: Toggle flip flop

Q10: What are the basic logic gates used for the implementation of S-R flip flops?

A10: NAND or NOR gates

EXPERIMENT NO: 11

AIM: To get familiar with the working and use of seven segment display.

THEORY: The seven-segment display has seven LED segments which are arranged in the shape of the digit '8' as shown in the Figure 3.1 below. It takes in a set of four bits as inputs, and based on the inputs a unique combination of LEDs start glowing. In such a display, a specific set of input patterns result in a specific digit being shown on the display by means of glowing LEDs. The way BCD digits from '0' to '9' get displayed.

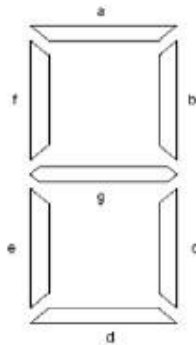

Figure 3.1: Seven-Segment Display

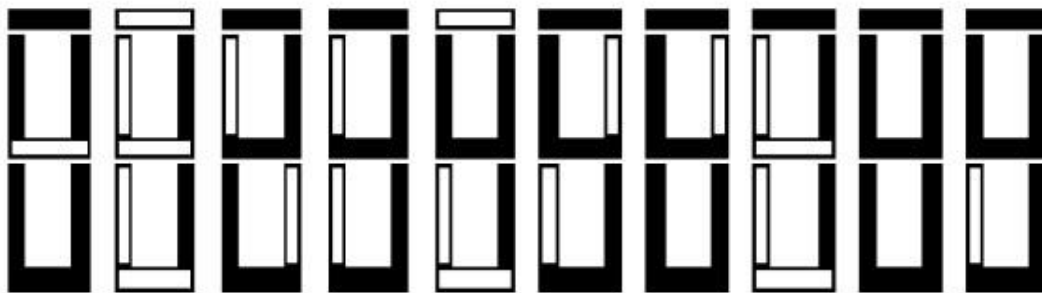

Figure 3.2: Digits 0-9 on the seven-segment display

BCD TO SEVEN-SEGMENT DRIVER CHIP

A BCD to seven-segment driver takes a BCD digit as input (usually 4 bits long) and decodes it into seven outputs which serve as the inputs for each of the seven segment of a seven-segment display. In the case shown in Figure 3.3, input A is the least significant bit and D is the most significant bit. The outputs bits of this decoder (a, b, c, d, e, f, g) correspond to the different segments on the Seven-segment display

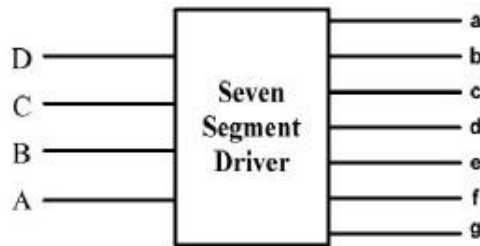

Figure 3.3: Seven Segment Display Driver Input /Output

QUIZ:

Q1:What is photoelectric effect?

A: Relationship between collection of light energy & reflection of electrons from a metal

Q2: How wavelength & energy of a photon is related?

A: Wavelength= $1.24 / \text{Energy}$

Q3: What is luminescence?

A: Property of light emission

Q4: What is seven segment display?

A: To display alpha numeric characters.

Q5: What is the application of DOT matrix display?

A: In instrumentation and process control, Test equipment, telecommunication etc.

Q6: What is the average value of current for the proper working of LED?

A: 20 ma

Q7: On what factor the sensitivity of a photodiode depends?

A: Light intensity & depletion region band-width

Q8: How the battery life of the display can be increased?

A: By turning off the display when not in use.

Q9: What are the applications of seven segment display?

A: Calculators, Microwave Ovens, Stereo Tuners, Digital Multimeter, Microprocessor Trainer Kits

Q10: What is the advantage of 14-segment display over seven segment?

A: Segment display is used for displaying alphanumeric characters.

BASICS OF ELECTRONICS(ECE-103-F)

EXPERIMENT NO.12

AIM: To Study Half – Wave Rectifier.

APPARATUS REQUIRED: Power supply, rectifier kit., CRO, Connecting Leads.

BRIEF THEORY: Rectification is a process of conversion of AC to DC. In half-wave rectifier, only one diode is used . During +ve half Cycle the diode is forward biased &, it conducts current through the load resistor R .During –ve half cycle diode is reverse biased Hence, no current flow through the circuit.Only +ve half cycle appears across the load, whereas, the –ve half Cycle is suppressed.

CIRCUIT DIGRAM:

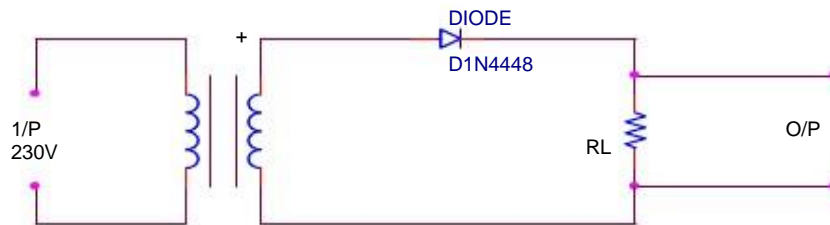

PROCEDURE :

1. Connect the ckt. as shown in fig.
2. Supply the input AC signal to the circuit.
3. Output signal is obtained on CRO which shows the DC(pulsating output).
4. Draw the wave form.

WAVE FORM :

Input wave

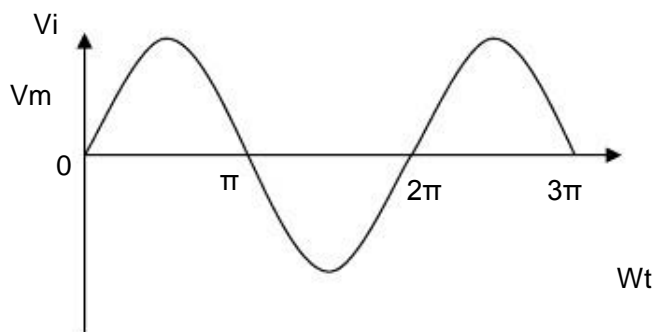

Output wave

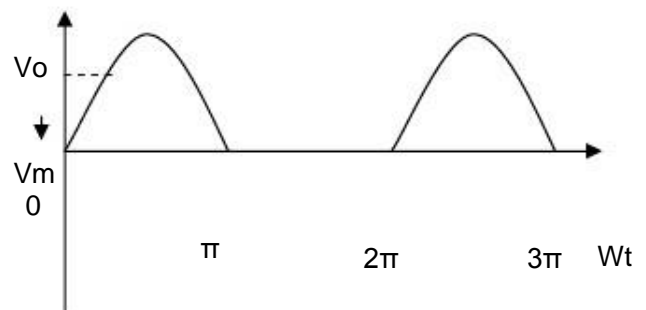

RESULT: Input and output waveform of half wave rectifier is as shown.

BASICS OF ELECTRONICS(ECE-103-F)

PRECAUTIONS:

1. Connection should be proper & tight.
2. Switch 'ON' the supply after completing the ckt.
3. Note down the input & output wave accurately.

QUIZ :

Q.1 Define Rectifier .

A. A circuit used to convert a.c. voltage into the pulsating d.c. voltage.

Q.2 What is Half-Wave Rectifier?

A. Rectifier in which diode conduct only for half cycle of waveform.

Q.3 Define PIV ?

A. Max. voltage which a diode can withstand without breakdown in reverse bias conditon.

Q.4 What type of output we get from H-W Rectifier?

A. In output we get unidirectional pulsating voltage.

Q.5 Write its Disadvantage?

A. Rectification efficiency is less & ripple factor is more.

Q.6 Define efficiency.

A. Ratio of d.c. power delivered to the load to the a.c. i/p power from sec. wdg. of transformer.

Q.7 Define Ripple Factor.

A. It is a measure of purity of output of a rectifier.

Q.8 What is the value of R_f for H-W Rectifier?

A. 1.21

Q. 9 What is Transformer utilization factor ?

A. Ratio of d.c. power delivered to the load to the a.c. rating of transformer secondary.

Q.10 What is the value of I_{rms} for HW Rectifier?

A. $I_m/2$.

EXPERIMENT NO. 13

AIM: To study Light Emitting Diode

THEORY:

The LED consists of a chip of semiconducting material impregnated, or doped, with impurities to create a p-n junction. As in other diodes, current flows easily from the p-side, or anode, to the n-side, or cathode, but not in the reverse direction. Charge-carriers—electrons and holes—flow into the junction from electrodes with different voltages. When an electron meets a hole, it falls into a lower energy level, and releases energy in the form of a photon.

The wavelength of the light emitted, and therefore its color, depends on the band gap energy of the materials forming the p-n junction. In silicon or germanium diodes, the electrons and holes recombine by a non-radiative transition which produces no optical emission, because these are indirect band gap materials. The materials used for the LED have a direct band gap with energies corresponding to near-infrared, visible or near-ultraviolet light.

LED development began with infrared and red devices made with gallium arsenide. Advances in materials science have made possible the production of devices with ever-shorter wavelengths, producing light in a variety of colors.

LEDs are usually built on an n-type substrate, with an electrode attached to the p-type layer deposited on its surface. P-type substrates, while less common, occur as well. Many commercial LEDs, especially GaN/InGaN, also use sapphire substrate.

Most materials used for LED production have very high refractive indices. This means that much light will be reflected back in to the material at the material/air surface interface. Therefore Light extraction in LEDs is an important aspect of LED production, subject to much research and development.

CIRCUIT DIAGRAM:

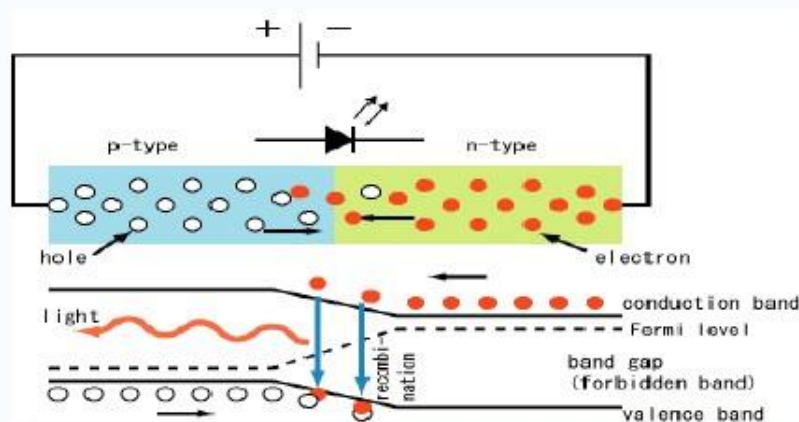

Advantages

- Efficiency: LEDs produce more light per watt than incandescent bulbs
- Color: LEDs can emit light of an intended color without the use of color filters that traditional lighting methods require. This is more efficient and can lower initial costs.
- Size: LEDs can be very small (smaller than 2 mm²) and are easily populated onto printed circuit boards.
- On/Off time: LEDs light up very quickly. A typical red indicator LED will achieve full brightness in microseconds. LEDs used in communications devices can have even faster response times.
- Lifetime: LEDs can have a relatively long useful life. One report estimates 35,000 to 50,000 hours of useful life, though time to complete failure may be longer. Fluorescent tubes typically are rated at about 10,000 to 15,000 hours, depending partly on the conditions of use, and incandescent light bulbs at 1,000–2,000 hours.
- Toxicity: LEDs do not contain mercury, unlike fluorescent lamps.

Disadvantages

- High initial price: LEDs are currently more expensive, price per lumen, on an initial capital cost basis, than most conventional lighting technologies.
- Temperature dependence: LED performance largely depends on the ambient temperature of the operating environment. Over-driving the LED in high ambient temperatures may result in overheating of the LED package, eventually leading to device failure.
- Voltage sensitivity: LEDs must be supplied with the voltage above the threshold and a current below the rating. This can involve series resistors or current-regulated power supplies.

QUIZ:

Q1. What does LED stand for?

A. L.E.D. stands for Light Emitting Diode

Q2. Is an LED a bulb?

A. LEDs do appear to be bulbs, but in fact are not. LEDs are tiny semiconductors encapsulated in plastic which protects their components and helps to focus the light.

Q3. What is the difference between an incandescent bulb and LED?

A. Incandescent creates light by the use of a filament. When power is applied, the filament glows and generates heat - which in turn produces light. LEDs are just the opposite. LEDs create light through a 'cold process'. When power is applied to semiconductors (usually gallium, arsenic and phosphorous), they're stimulated by the movement of electrons, this creating photons. Photons are the light that is visibly seen by humans.

Q4. Do LEDs have a wire filament?

A. No, LEDs operate using entirely different components. LEDs are diodes - they only allow power to move in one direction. The anode (+) is where the current comes in and the cathode (-) is where

BASICS OF ELECTRONICS(ECE-103-F)

the current goes out, much like the positive and negative terminals of a battery. Incandescent bulbs project light in every direction (omni directional) as opposed to LED lights which project light in specified directions (such as 20, 50 and 120 degrees) due to their package design and layout.

Q5. Why do LEDs use such little power?

A. LEDs do not use a filament where a conductor is heated and light is created. Filament based lighting consumes more power than the light produced. LEDs produce very little amounts of heat and do not use filaments making them far more efficient in consumption and output.

Q6. Do LEDs produce heat?

A. LEDs produce very little amounts of heat. The heat noticed in some instances is due to on board components and other factors of the circuit. In comparison to incandescent, LEDs produce a fraction of the heat. If LEDs are hot to the touch, they are being overpowered due to improper circuitry.

Q7. Can LEDs be damaged if hooked up backwards?

A. Yes, they can. LEDs are diodes and only allow power to pass in one direction. To ensure that you will get the most life out of LED devices, additional circuits are added to prevent this from occurring in both AC and DC applications.

Q8. Are LEDs affected by extreme conditions?

A. LEDs are geared for harsh environments. LEDs function from -40F to 180F. There is no delay or required "warm up time" for LEDs to function.

Q9. How long do LEDs last?

A. LEDs are rated by manufacturers to operate under normal conditions for approximately 10 years or 100,000 hours of continuous use. As LEDs get older, they tend to dim and fade but aren't susceptible to blinking like incandescent or fluorescents.

Q10. LEDs are more expensive than other lighting options. Why?

A. LEDs can operate as stand alone devices, but when grouped or clustered they require additional steps to operate properly. LEDs need proper components such as a circuit board, driving components and some cases and housings to endure the elements. LED circuits can be designed rapidly, but to ensure that they operate correctly and for long periods of time they require testing.